

02 Shingle application guide

- 03 General conditions
- 03 Material requirements
- 04 Terms
- 09 Estimating shingle requirements
- 10 Roof preparation
- 12 Shingle application

16 Инструкция по установке

- 17 Общая информация
- 17 Используемые материалы
- 18 Терминология
- 23 Расход битумной черепицы
- 24 Подготовка кровельного основания
- 26 Установка черепицы

30 Ghid de montaj

- 31 Conditii generale
- 31 Cerintele materialului
- 32 Termeni
- 37 Estimarea cerintelor placilor de sindrila bitumata
- 38 Pregatirea acoperisului
- 40 Montajul placilor de sindrila bitumata

44 Zsindely felrakási útmutató

- 45 Általános feltételek
- 45 Anyagszükséglet
- 46 Elnevezések
- 51 Zsindelyigény felmérése
- 52 Tető előkészítése
- 54 Zsindely felrakás

CONTENTS

Shingle Application Guide

- 03 General conditions
- 03 Material requirements
- 04 Terms
- 09 Estimating shingle requirements
- 10 Roof preparation
- 12 Shingle application

GENERAL CONDITIONS

- IKO assumes no responsibility for leaks due to improper application, or failure to properly prepare the roof surface. Shingles may not be installed directly over insulation; flow-through ventilated air space must be provided between the insulation and the nailable deck.
- Do not mix different production dates/codes on the same roof surface.
- Colour shading is inherent to shingles and is not a defect. In order to minimise shading, shingles should be picked and mixed randomly from different bundles and placed across and diagonally up the roof.
- Do not rack the shingles up the roof !
- Do not remove the tape from the back of the shingles. It is for packaging purposes and not for sealing.
- However, release film on the back of the **ArmourShield**, **DiamantShield** and **BiberShield** shingles must be removed during application. (Figure 7 - 7)
- The factory applied sealing strip will become effective when exposed to the heat of the sun. Hand sealing is necessary for cold weather and steep slope application. Plastic cement must be approved by IKO to be compatible with IKO shingles.
- Bend bundle before opening for easier separation.
- Caution: During sunny, hot periods, avoid stepping on shingles on the sunny side of the roof to prevent marking.

MATERIAL REQUIREMENTS

- Shingles:
IKO's selection of ± 60 different types and colours of fibreglass based oxidised and APP modified bitumen shingles.
- Underlay: (Not all are required - see instructions)
IKO Armourbase Pro,
IKO Armourbase 30, a 3,0 mm glassfibre based oxidised bitumen membrane.
IKO Armourbase 15, a 1,5 mm glassfibre based oxidised bitumen membrane.
IKO Armourbase Premium SA, a self-adhesive membrane.
- Valley Coverings: (for Open Valley Method)
IKO Armour Valley: a 4,0 mm APP modified membrane in matching shingle colours, or metal flashing.
- Drip Edges:
Metal drip edges for the eaves and rakes.
- Fasteners:
Corrosion resistant nails 25 mm in length and a head diameter of 10 mm.
The shaft should be 3 mm in diameter and barbed.
Cambridge shingles and nailing of hips and ridges require nails 30 mm in length.
- Plastic Cement:
IKO Shingle Stick or an IKO approved plastic cement.
- Vents:
Sufficient vents to satisfy minimum venting requirements.
(Ask IKO or your local dealer for a Ventilation brochure)

Figure 1a.

1. Exposure
2. Headlap
3. Cut-outs
4. Self Sealing Strip
5. Tabs

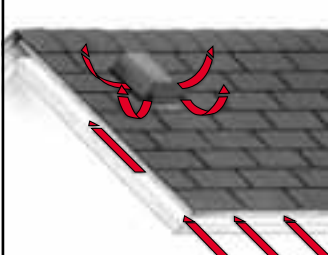
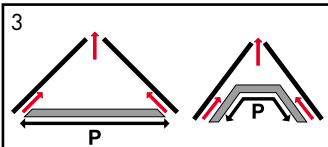
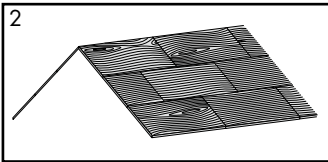
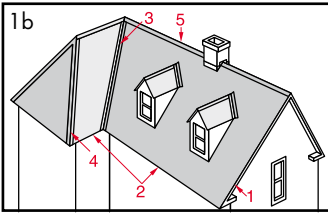
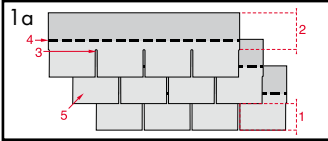
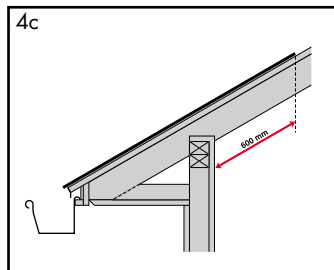
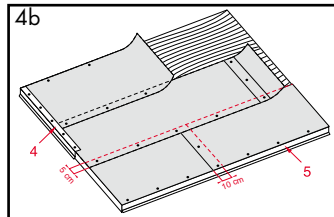
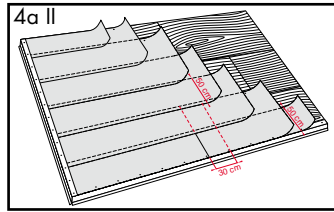
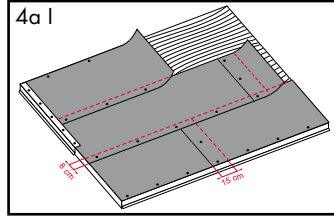

Figure 1b.

1. Rakes
2. Eaves
3. Valleys
4. Hips
5. Ridges



6a



6b I

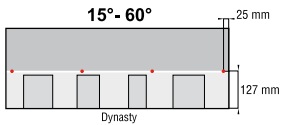
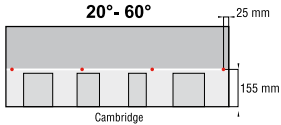
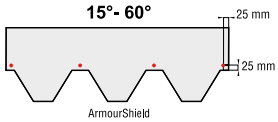
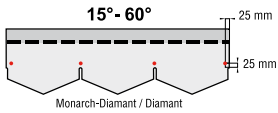
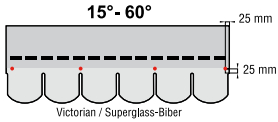
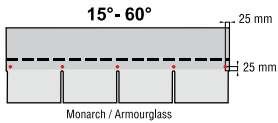
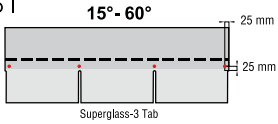

6b II

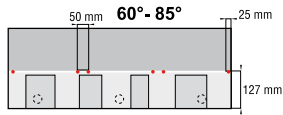
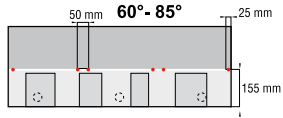
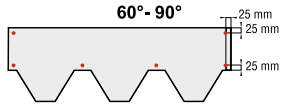
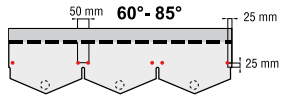
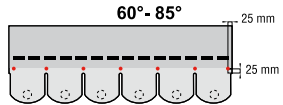
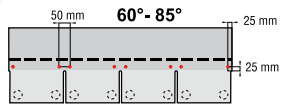
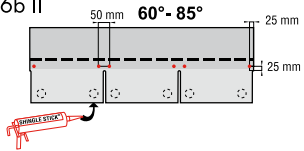

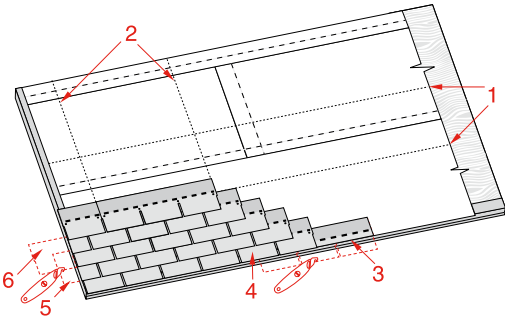

Superglass - 3 Tab

Armourglass - 4 Tab
Monarch - APP

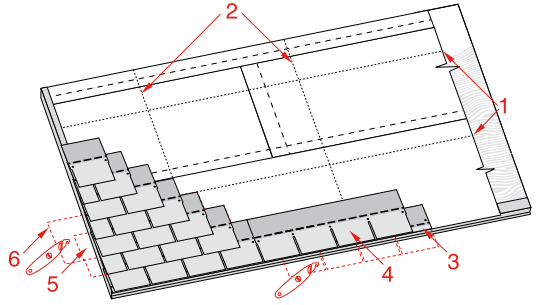

Cambridge

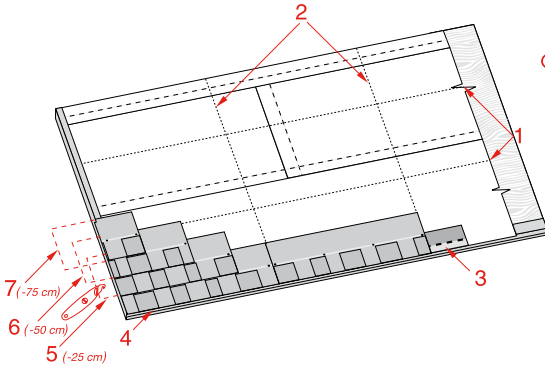

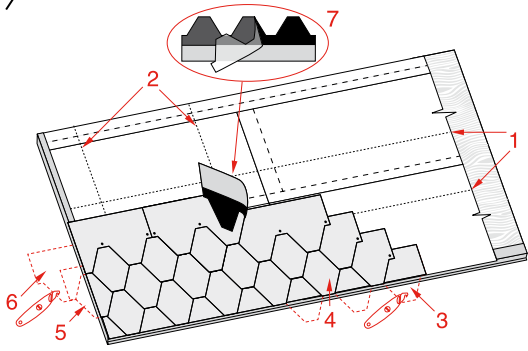

ArmourShield

Diamant
Monarch - Diamant
DiamantShield

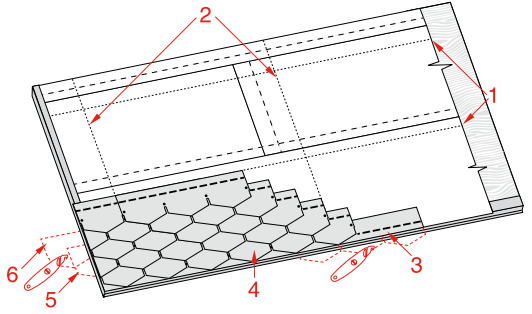

Victorian
Superglass - Biber
BiberShield

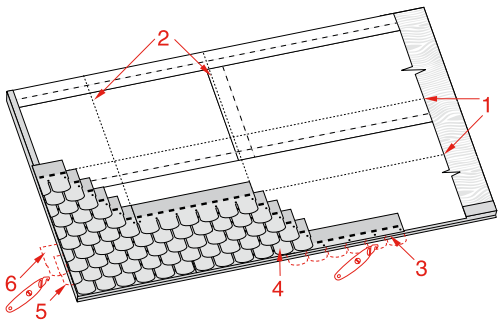

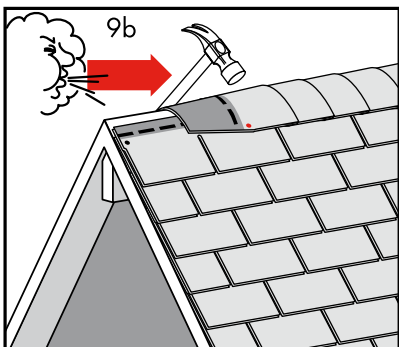
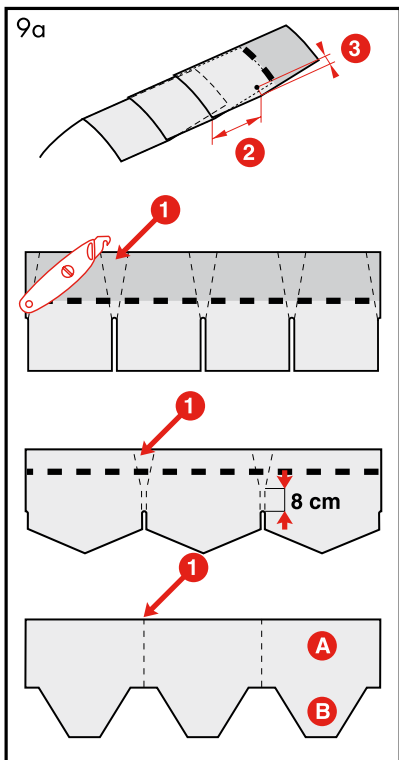
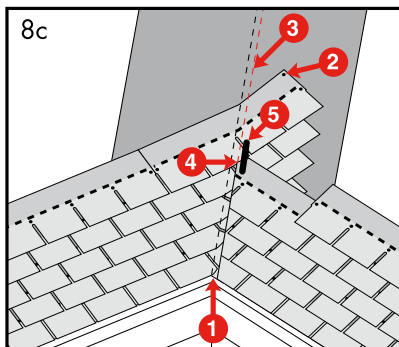
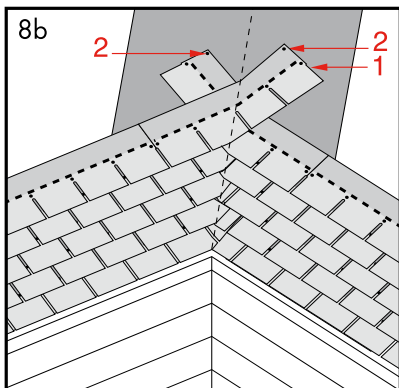
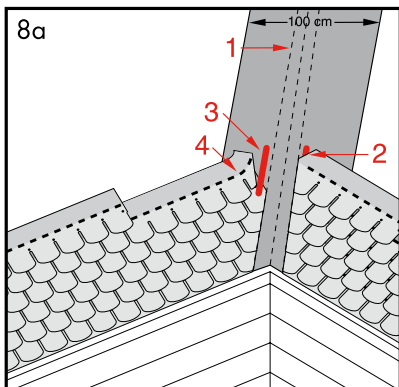

ESTIMATING SHINGLE REQUIREMENTS

I. For the Roof Deck.

Shingle exposure is in function of the roof pitch as displayed in the table below.

Shingles may not be applied on roof pitches not specified.

Certain countries may have different regulations.

Check local building codes.

II. For the Hips and Ridges.

A good approximation is to order an extra 10 - 15 % material (depending on the amount of roof detail) for coverage of the hips, ridges and starter strip.

When applying Victorian or Superglass-Biber shingles be sure to order rectangular shingles in matching colour to cover hips and ridges.

For Cambridge, order 'Marathon Ultra'.

Shingle type	Roof pitch	Exposure	Roof coverage/Bundle	± kg/m ²
Cambridge	20°- 85°	15,5 cm	3,10 m ²	12,2
Armourglass	15°- 25°	12,5 cm	2,62 m ²	12,5
	26°- 85°	14,3 cm	3,00 m ²	10,9
Victorian	15°- 25°	11,5 cm	2,41 m ²	13,1
	26°- 85°	13,0 cm	2,75 m ²	11,5
BiberShield	15°- 90°	13,0 cm	2,47 m ²	12,1
Diamant	15°- 25°	9,7 cm	2,62 m ²	12,0
	26°- 85°	11,2 cm	3,00 m ²	10,5
DiamantShield	15°- 90°	11,2 cm	2,46 m ²	11,2
ArmourShield	15°- 90°	13,4 cm	3,00 m ²	9,4
Superglass - 3 Tab	15°- 25°	12,5 cm	2,62 m ²	11,0
	26°- 85°	14,3 cm	3,00 m ²	9,7
Superglass - Biber	15°- 25°	11,5 cm	2,65 m ²	11,4
	26°- 85°	13,0 cm	3,00 m ²	10,1
Monarch	15°- 25°	12,5 cm	2,25 m ²	13,5
	26°- 85°	14,3 cm	2,58 m ²	12,1
Monarch - Diamant	15°- 25°	9,7 cm	2,13 m ²	13,5
	26°- 85°	11,2 cm	2,46 m ²	11,7

Example: Shingle type: Armourglass
 Roof Pitch: 32°
 Roof Surface: 240 m²
 Calculation: Roof Pitch 26°- 85° = 3,00 m²/bundle
 240 m² / 3,00 = 80 bundles

ROOF PREPARATION

I. ROOF DECK (Figure 2)

The roof deck must be smooth, firm, dry and securely fastened.

The deck should be made of good quality plywood, sheathing boards or nonveneer structural panels (wafer or strandboard). Wooden boards can be maximum 15 cm wide. All wood products must be properly conditioned to be at moisture equilibrium. Decking should be installed in a staggered manner and sufficiently supported. Failure to use proper decking material which can provide a rigid deck surface can result in deck movement which can damage the shingles.

II. VENTILATION (Figure 3)

It is essential to allow heat dissipation and water vapor to escape the roof system through proper ventilation. Therefore, air must be able to circulate freely between insulation and the nailable roof deck, from the eaves to the ridges. On roof pitches 15°- 25° min. net free ventilation area is 33 cm², on 25°- 85° min. net free ventilation area is 16 cm² for each 1 m² of insulated ceiling area (P), always divided evenly between the eaves and the ridge.

III. UNDERLAY

Install as flat as possible to prevent unevenness from being projected in the shingle surface. Install parallel to the eaves.

Slopes 15°- 20°

Option 1: (Figure 4a I)

It is advised to cover the entire roof deck with **IKO Armourbase Premium SA** or a similar modified base sheet which will seal the entire deck.

End laps must be 15 cm and horizontal laps 8 cm.

Option 2: (Figure 4a II)

Use **IKO Armourbase Pro** or a similar base sheet, to provide a double coverage of underlay to the roof deck. Cut a starter strip 50 cm wide and lay succeeding courses fastened with 50 cm horizontal laps and 30 cm end laps.

Slopes 21°- 85° (Figure 4b)

The entire roof deck should be covered with **IKO Armourbase Pro** or an approved shingle underlay. The underlay should be installed parallel to the eaves with a 5 cm horizontal lap and 10 cm end laps. Secure the underlay with only enough nails to hold it in place.

Slopes 85°- 90°

No underlay required. Only **ArmourShield**, **DiamantShield** and **BiberShield** shingles can be applied.

IV: VALLEYS

One may follow either the Open, Woven or Closed Cut method for shingle application in the roof valleys. Valley preparation depends on the method:

- Open Valley Preparation (Figure 5).

Cover the valleys with 1 m wide underlayment, **Armourbase 30** (1). Vertical laps must be 30 cm and cemented (2). The end laps from the roof deck underlay must overlap the valley by 15 cm (3). Finish the valleys by applying the **IKO Armour Valley** or metal flashing on top of the underlay in the valleys (4). Nail the Bi-Armour Valley at 40 cm intervals 2,5 cm from the edge. If lapping is unavoidable it must be 30 cm and cemented or torched (5). Metal flashing should be fastened every 25 cm and overlaps should be 30 cm and cemented.

- Woven or Closed Cut Valley Preparation.

Prepare the valley with one layer of **IKO Armourbase Premium SA** with 30 cm laps. Alternatively, use a layer of **Armourbase 30** or an approved shingle underlay, nailed 2,5 cm from the edge. Laps should be 30 cm and cemented.

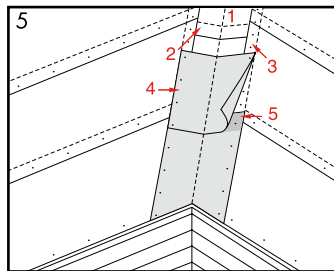

V. EAVES PROTECTION (Figure 4c)

In climates where average January temperatures are -1°C , eaves should be protected against ice damming which can cause water to back up the roof under the shingles. Apply **IKO Armourbase Premium SA** from the eaves to the least 60 cm beyond the inside wall line. Use 8 cm horizontal laps and 15 cm end laps.

Alternatively, use **Armourbase 30** and provide a double coverage of underlay to the eaves. Cut a starter strip 50 cm wide and lay succeeding courses cemented with 50 cm horizontal laps and 30 cm end laps to a distance 60 cm beyond the inside wall line.

VI. DRIP EDGES (Figure 4b)

Drip edges for the rakes and eaves of the roof should be made of corrosion-resistant material which extends at least 8 cm from the edge and bends downward over them. Drip edges should be applied over the underlay at the rakes (4) and under the underlay at the eaves (5).

VII. CHALK LINES (Figure 7)

Chalk lines provide visual guides that help align the shingles horizontally and vertically. They also align shingles on each side of a dormer or chimney. Horizontal lines can be snapped every 4 to 5 courses (1) and a vertical line (2) should be used on long shingle runs where a line is snapped in the centre of the run and shingles are applied to the left and right of the line.

All chalk lines are to be considered as guiding lines not application lines.

SHINGLE APPLICATION

I. NAILING & SEALING

Proper fastening is essential for a good roof. Drive the nails straight so that the nail heads are flush with, but not cutting into the shingle surface (Figure 6a). Always nail 2,5 cm above the cut-out and 2,5 cm from each edge. For correct positioning and nail quantities per type of shingle and roof slope see Figure 6b I. Note that steep slope application ($> 60^\circ$) or high wind areas require extra nails and hand sealing with **IKO Shingle Stick** as shown in Figure 6b II. During cold weather application extra cement must be added in the same manner. In high wind areas the tabs of each shingle should be cemented for at least the top five courses of the roof. Plastic cement should be applied in amounts no greater than 25 mm in diameter and used sparingly.

Nail position for **Cambridge**: WHITE LINE = NAILING LINE.

STARTER STRIP (Figure 7)

Prepare the starter strip by cutting off the shingle tabs along a line level with the top of the cut-outs. Begin the starter strip by cutting the strip half a tab short so that its joints will not line up with the joints of the first course of shingles. The starter strip should overhang the eaves by 6-10 mm and the rakes where applicable (3).

For **Cambridge** use rectangular shingles.

FIRST COURSES & APPLICATION PROCEDURE (Figure 7)

First course (4):

Start with a complete shingle applied flush with the starter strip at rake and eaves.

Nail as shown in Figure 6a and continue across the roof with full shingles.

Second course (5):

Cut half a tab from a shingle and start at the rake end. Nail the shingle so that the lower edge of the tabs is flush with the top of the cut-out of the shingle in the first course. (Adjust as needed for roof slopes requiring different exposures, see p.7 table/exposure).

Third and succeeding courses (6):

Start the third course with a shingle from which a full tab has been cut. Cut off an additional half tab for each succeeding course. For maximum protection against wind driven rain, cement the shingle at the rake edges.

Attention: When applying **Cambridge** or **Dynasty** shingles, trim off 25, 50, 75, ... cm respectively from the left end of the first shingle in the second (5), the third (6), the fourth (7), ... course.

II. SHINGLE APPLICATION IN VALLEYS

Open Valley Method (Figure 8a)

Snap two chalk lines from the ridge to the eaves 8 cm apart increasing in width by 1 cm per meter toward the eaves (1). Trim the shingles to these lines and cut a 5 cm triangle off the top corner to direct the water into the valley (2).

Glue the valley end of each shingle with IKO Shingle Stick (3) and nail the shingles 5 cm back from the chalk line (4).

Woven Valley Method (Figure 8b)

Install the shingles through the valley intersection. The last shingle should extend at least 30 cm onto the intersecting roof surface (1) fastened with an extra nail at the upper corner of the shingle (2). Press the shingles tightly into the valley before nailing. No nailing within 15 cm of the valley centerline.

Closed Cut Method (Figure 8c) for slopes $\geq 23^\circ$

For best performance: start applying on roof plane with the lower slope or biggest surface. The starter strip must be woven (1) (extend +25 cm onto adjoining roof plane). Do not nail within 15 cm of valley centerline. Use one extra nail (2) at the end of each shingle crossing the valley. After completing this roof plane, snap a chalk line (3) 5 cm from centerline on roof plane still to cover. Apply the shingles onto second plane, trim shingles to the line and cut a 5 cm triangle (4) off the top corner to direct the water into the valley.

Glue the valley end of each shingle with IKO Shingle Stick (5).

III. HIPS and RIDGES (Figure 9a & 9b)

Adjust the last few courses of shingles so that the ridge capping will adequately cover the top courses of shingles equally on both sides of the ridge. Cut rectangular and diamond shaped shingles into individual pieces by dividing the shingle at the cut-outs (1). (ArmourShield: (A) is visual part, (B) is covered part). (Figure 9a)

Apply the hip and ridge shingles double thickness by stacking two pieces and bending them over the hip or the ridge.

In cold weather warm the shingle before bending.

Nail the capping 16 cm from the tab edge (2) and 2,5 cm from each side (3).

Start application from the end of the ridge opposite the direction of the prevailing winds. (Figure 9b)

IV.FLASHINGS

Chimneys (Figures 10a)

Step Flashing (Figures 10b)

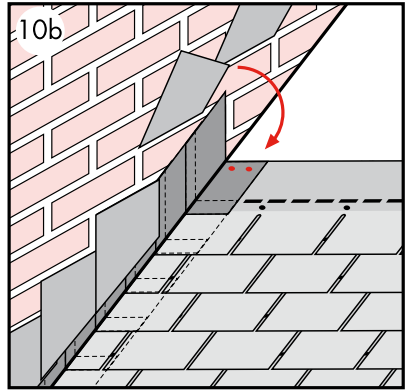
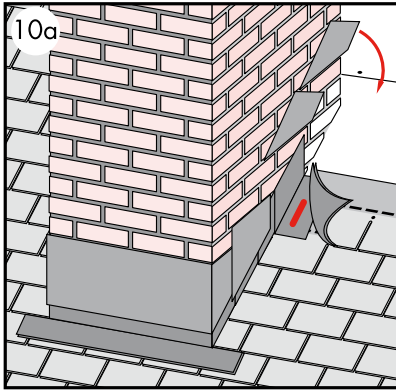

Reroofing with **Cambridge** roofshingles.

